



BEST CRAFT ORGANIZER

LARGE CABINET FOR BEAD STORAGE SOLUTIONS



Quick-Fit Dowel (16)



Wood Dowel (20)



Cam Locks (24)

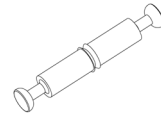

Short Connector Bolt (4)

You will need: Phillips Screwdriver

- 1.) Insert the Quick-Fit Dowels into the inside holes shown on the top, bottom (with small pilot holes), and side panels.

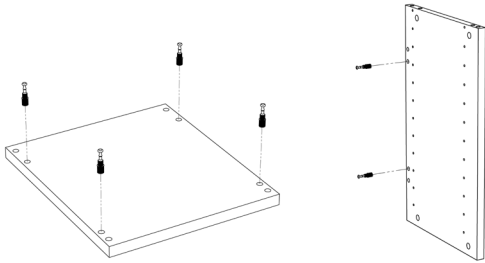

- 2.) Insert the Wood Dowels into the outside holes shown on the top, bottom, and side panels.

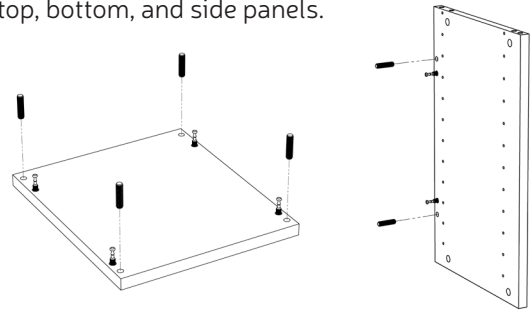

- 3.) Insert the Cam Locks into the larger holes on the back and side panels. Make sure the arrow on the Cam Lock is pointing towards pre-drilled hole in edge of panel.

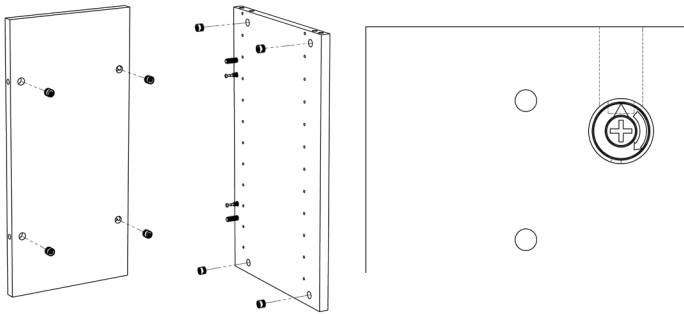

- 4.) Attach Rails to left and right side panels, saving the top Rail for a later step.

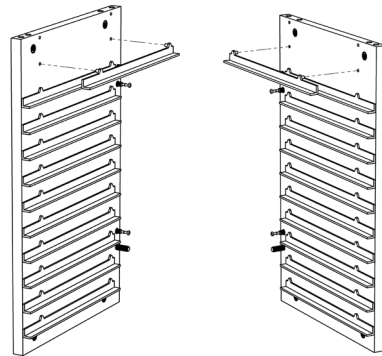

- 5.) Lay the back panel on the floor with the Cam Locks facing up. Attach both side panels to the back panel by sliding the Quick-Fit Dowel into the pre-drilled holes on the edge of the back panel. Tighten the Cam Locks by turning clockwise. Complete this step twice to prepare two identical assemblies.

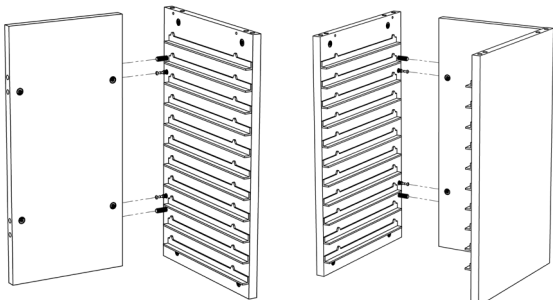

COMPLETE THIS STEP TWICE!

- 6.) Flip over one of the assemblies from step 5 and attach the bottom panel, tightening the Cam Locks in the same manner. Ensure that Rails match the orientation shown below.

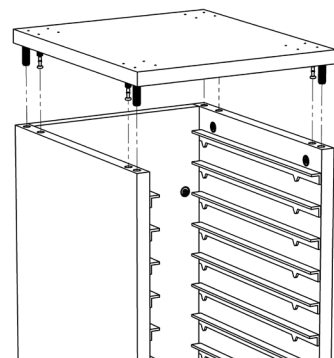

7.) Flip over the assembly from step 6 and insert Short Connector Bolts and Wood Dowels in the holes shown.

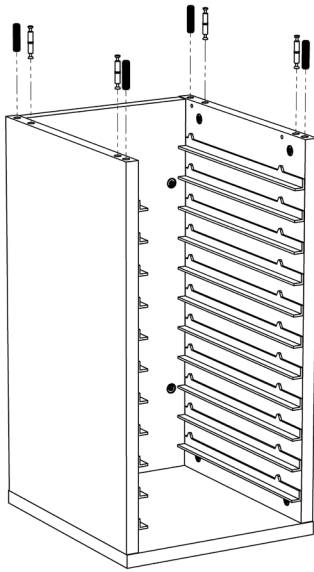

8.) Attach the top panel to the other assembly from step 5, tightening the Cam Locks in the same manner. Ensure that Rails match the orientation shown below.

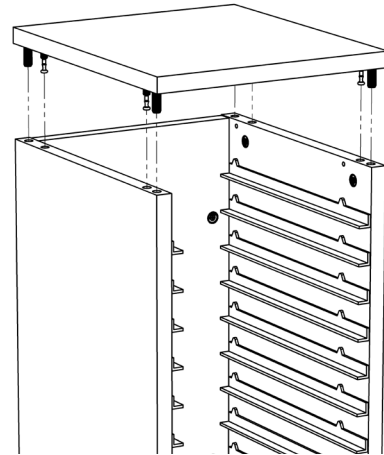

9.) Stack the two assemblies and tighten the Cam Locks by turning clockwise.

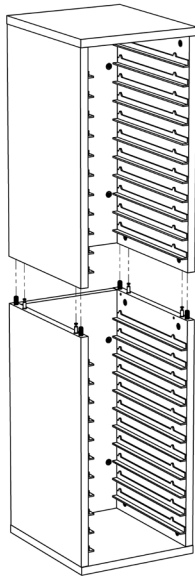

10.) Attach the final set of Rails to the sides in the top holes.

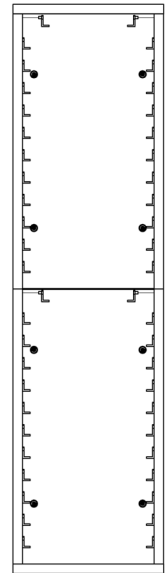

9.) Skip this step if you did not purchase Casters. Attach optional Casters to the bottom using the pre-drilled holes. Be sure to lock Casters before flipping cabinet back over.

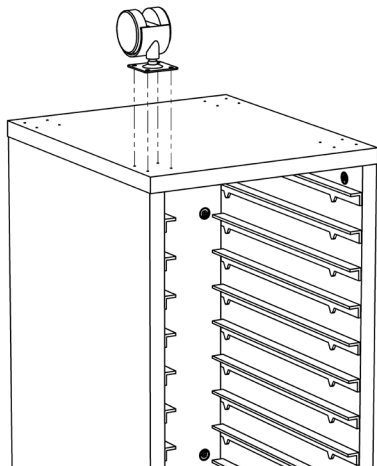

COMPLETED CABINET

