

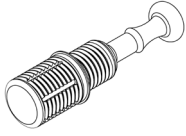

BEST CRAFT ORGANIZER

LARGE STORAGE CABINET - SINGLE



Quick-Fit Dowel (16)

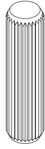

Wood Dowel (20)



Cam Locks (24)

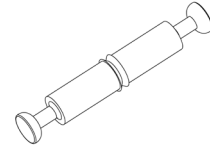

Short Connector Bolt (4)

You will need: Phillips Screwdriver

- 1.) Insert the Quick-Fit Dowels into the inside holes shown on the top, bottom (with small pre-drilled holes), and side panels.

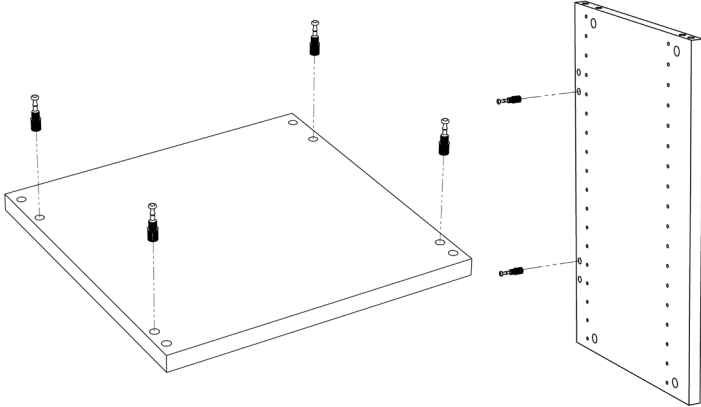

- 2.) Insert the Wood Dowels into the outside holes shown on the top, bottom, and side panels.

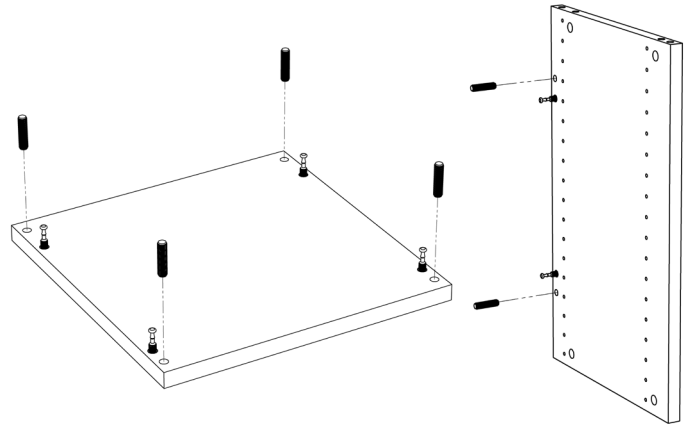

- 3.) Insert the cam locks into the larger holes on the back and side panels. Make sure the arrow on the cam lock is pointing towards pre-drilled hole in side of panel.

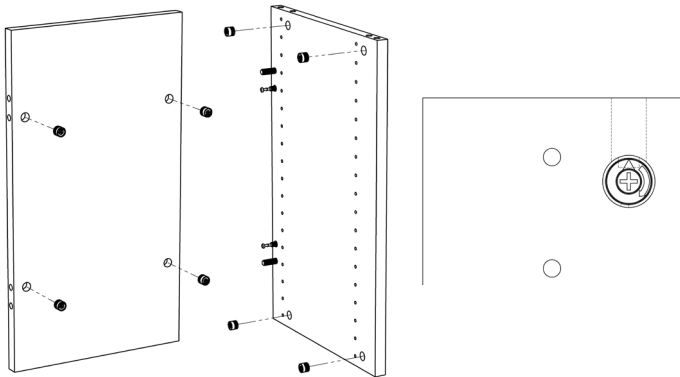

- 4.) Lay the back panel on the floor with the cam locks facing up. Attach both side panels to the back panel by sliding the cam lock bolts into the pre-drilled holes on the edge of the back panel. Tighten the cam locks by turning clockwise. Complete this step twice to prepare two identical assemblies.

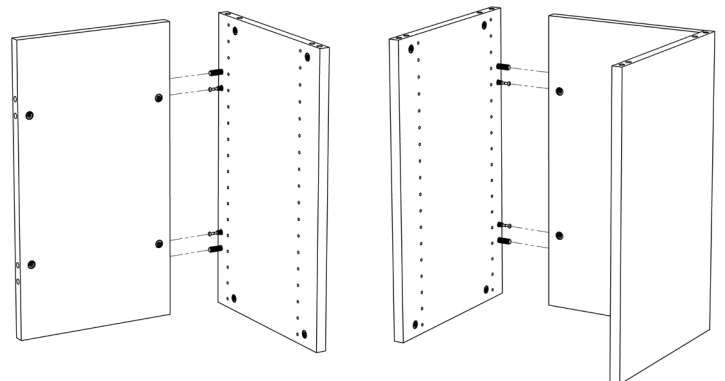

COMPLETE THIS STEP TWICE!

5.) Attach the top panel to one of the assemblies from step 4, tightening the cam locks in the same manner.

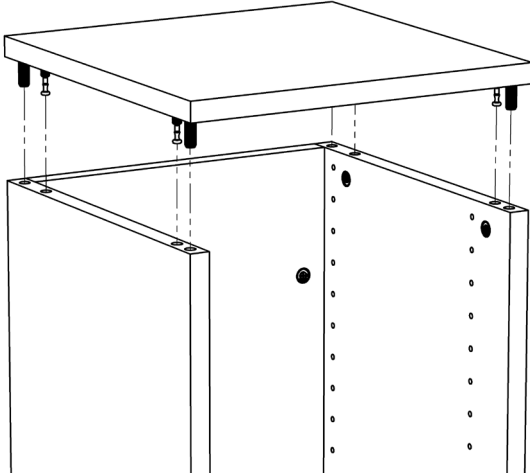

6.) Flip over the assembly from step 5 and place Short Connector Bolts and Wood Dowels in the holes shown.

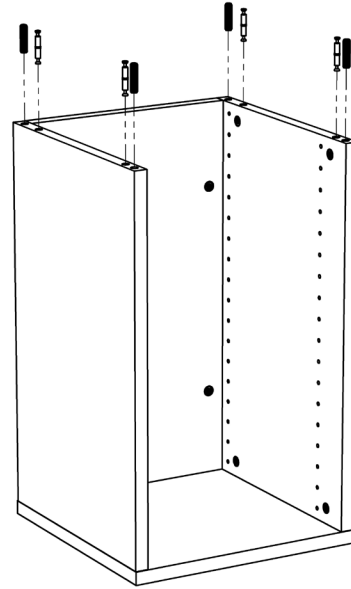

7.) Attach the bottom panel to the other assembly from step 4, tightening the cam locks in the same manner.

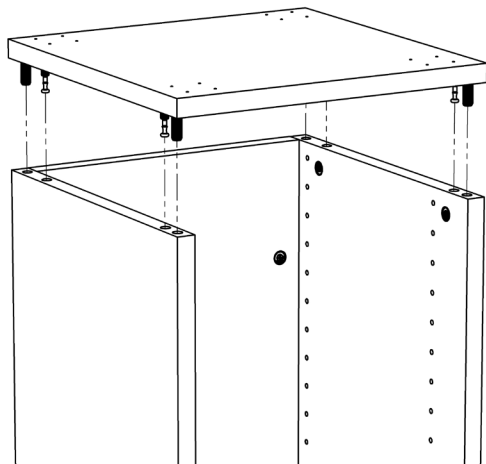

8.) Attach optional casters using the pilot holes.

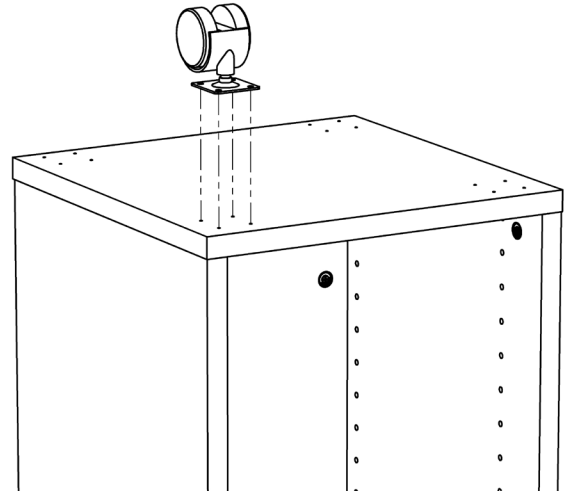

7.) Stack the two assemblies and tighten the cam locks by turning clockwise.

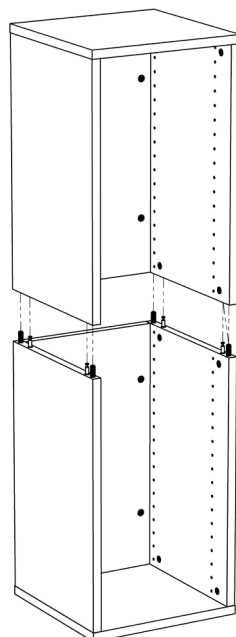

COMPLETED CABINET

Please note: Drawer Rails are not required for the bottom drawer.

